

TUBES	5/8" x 0.049" 316SS SA249
FINS	8 FPI ALUMINUM
HEADERS	3" SCH10 316SS
FRAME	CARBON STEEL
HAIL GUARD	CARBON STEEL

REVISIONS			
REV	DESCRIPTION	DATE	APPR
A	ORIGINAL RELEASE	3/12/2018	HDE

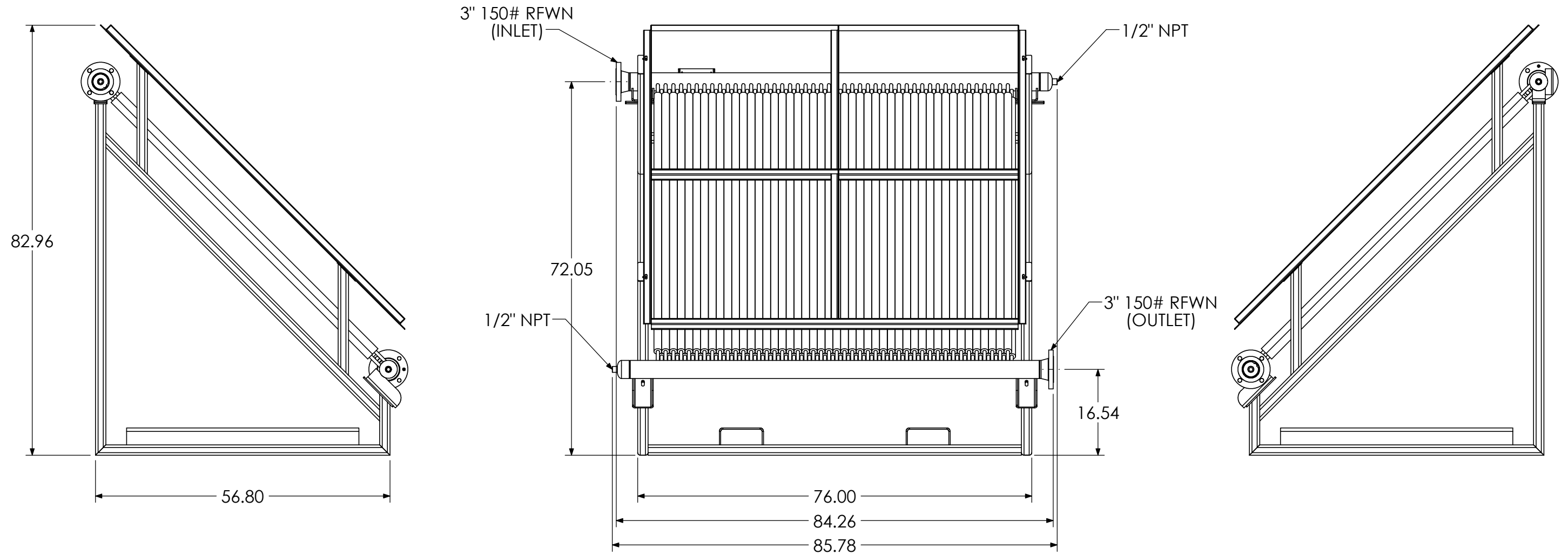

DESIGN INFORMATION			
DESCRIPTION	DESIGN TEMPERATURE	DESIGN PRESSURE	TEST PRESSURE (PNEUMATIC)
ASC-70X70-2R-58/72	400°F	25 PSIG	27.5 PSIG

UNLESS OTHERWISE SPECIFIED:		NAME	DATE	EXACT EXCHANGER INCORPORATED PO BOX 795187 DALLAS, TX 75379-5187 (O) 972-466-1999 or 800-443-9228 (F) 972-466-1878	
DIMENSIONS ARE IN INCHES		DRAWN	HDE		TITLE: OUTLINE DRAWING
TOLERANCES:		CHECKED	MNS		
ANGULAR/BEND ± 2°		ENG APPR.	MNS		
TWO PLACE DECIMAL ±0.125		MFG APPR.	DNS		
THREE PLACE DECIMAL ±0.063		COMMENTS:		SIZE B DWG. NO. 318003 REV A	
PROPRIETARY AND CONFIDENTIAL THE INFORMATION CONTAINED IN THIS DRAWING IS THE SOLE PROPERTY OF EXACT EXCHANGER. ANY REPRODUCTION IN PART OR AS A WHOLE WITHOUT THE WRITTEN PERMISSION OF EXACT EXCHANGER IS PROHIBITED.		DO NOT SCALE DRAWING		SCALE: 1:20 EST WEIGHT: 869.79 SHEET 1 OF 1	